



MAG-B

HORIZONTAL FORM FILL SEAL MACHINE

F&T

FLEXIBLES
& TRAYS

MAG-B

HORIZONTAL FORM FILL SEAL MACHINE

Bartelt's MAG-B Horizontal Form Fill Seal Machine transforms pouch packaging with its pitch-less operation and fast, tool-free changeovers. It replaces mechanical systems with a contactless magnetic track and patented, maintenance-free bag clamps, reducing wear and supporting a wide range of film substrates. Its open, sanitary design and IP69K-rated washdown track make it ideal for food and personal care, while recipe-based controls and efficient film handling support recyclable and mono-material films.

The MAG-B's compact footprint and industry-first magnetic motion system enables an output of 150 pouches per minute. Scalable for future needs, it supports new sizes, faster speeds, and thinner films. As part of the MAG Series, it offers modular options like zipper modules, nitrogen flushing, and film splicing, making it a future-ready solution for evolving production demands.



INDUSTRIES SERVED

- Agriculture
- Candy and Confectionery
- Cheese and Dairy Products
- Dried Meats
- Household Chemicals
- Nutraceuticals, Vitamins, and Supplements
- Pet Care Solutions
- Snack Foods

POUCHES

- 3-Sided Fin Seal
- 4-Sided Fin Seal
- Delta-Pac Stand-up
- Doy Stand-up
- Frangible Seal
- Gusset Bottom
- Membrane Seal Pouch
- Tandem Fin Seal
- Zipper Pouch

MAG-B FEATURES



ADAPTIVE SEAL CONTROL
Automatically adjusts positioning in real time to ensure optimal seal quality and maximize uptime.



MAGNETIC MOTION TRACK
Enables precise, flexible operation, seamlessly transitioning between simplex and duplex mode.

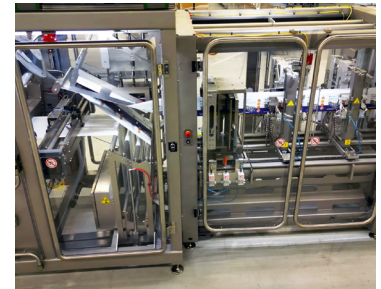

OPEN-FRAME DESIGN
Allows easy maintenance access and minimizes product buildup for improved hygiene and efficiency.



DYNAMIC PRODUCT SETTLING
Promotes clean, debris-free top seals for enhanced reliability and performance.



MAGNETIC GRIPPERS
Durable and maintenance-free, delivering a strong hold, reduces product buildup, and are easy to clean.



MODULAR DESIGN
Customizable configuration that supports a wide range of packaging applications.

CONFIGURATION

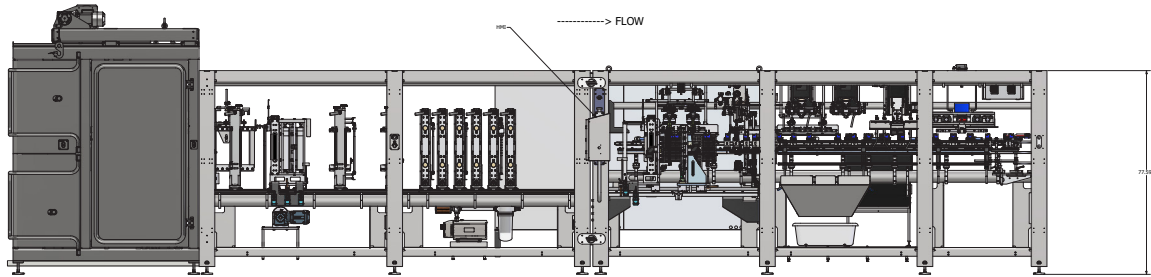
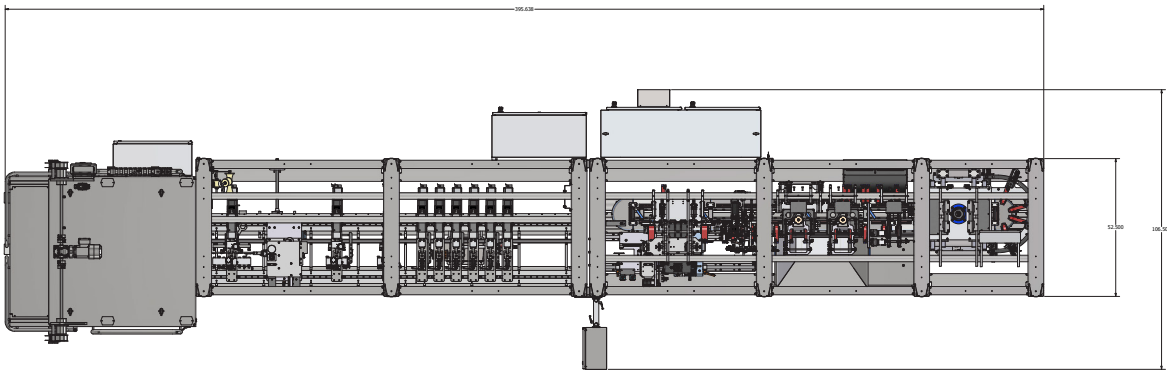

Contact Bartelt to learn about packaging machinery tailored to your unique requirements.

FEATURES & BENEFITS

Adaptive Machine Layout

Seamlessly integrate into any production environment to enhance productivity and efficiency.

Automatic Film Tracking on Seals

Continuously monitors and adjusts film alignment during sealing to ensure reliable seals and minimize leaks or product loss.

Linear Motion Track

Magnetic track ensures precise, flexible transitions between simplex and duplex formats to support diverse packaging needs.

Reduced Footprint

Maximizes efficiency without requiring additional floor space, ideal for facilities with space constraints.

Simplex or Duplex Configuration

Supports multiple pouch formats in a single machine, enhancing production flexibility and utilization.

POUCH DIMENSIONS

	SIMPLEX	DUPLEX
Width	5.0" (127mm) to 15" (381 mm)	5.0" (127mm) to 9.0" (229 mm)
Height	5.0" (127mm) to 15" (381 mm)	5.0" (127 mm) to 15" (381 mm)
Gusset	Up to 5.0" (127 mm)	Up to 5.0" (127 mm)
Fill Weight	Up to 5 lbs. (2.27 kg)	Up to 5 lbs. (2.27 kg)
Output (cpm)*	Up to 75 PPM	Up to 150 PPM

ELECTRIC & CONTROL

Construction	Beckhoff, BNR, or AB Magnetic Tracks
Flow	24 SCFM
Frequency	60Hz
Pressure	80 PSI (5.52 bar)

MECHANICAL SPECS

Machine Dimensions	Length - 395.638" Width - 52.5" - 106.504" Height - 77.594"
Machine Weight	22,000 lb
Core Diameter	6
Max Web Roll	Width: 34, Diameter: 24

*Productivity may vary depending on operator skill, packaging material quality, product characteristics, and overall machine configuration.



About Bartelt Packaging

Bartelt is a trusted manufacturer of pouching and cartoning systems, providing dependable and long-lasting solutions to food and non-food industries. Bartelt also operates as the master distributor for both FLtècnics' rollstock and pre-made pouch machines. As the world's first developer of intermittent motion horizontal form fill seal pouching machines, Bartelt is a true pioneer in automated packaging. From simple to advanced applications spanning primary and secondary packaging, quality components and a durable design are incorporated into every solution. Bartelt is a product brand of ProMach, a global leader in packaging line solutions. As part of the ProMach Flexibles & Trays business line, Bartelt helps our packaging customers protect their products and earn the trust of their consumers. ProMach is performance, and the proof is in every package. Learn more about Bartelt at www.BarteltPackaging.com and more about ProMach at www.ProMachBuilt.com

BARTELT PACKAGING, LLC
5501 N. Washington Blvd.
Sarasota, FL 34243

P: 941-359-4000
E: Bartelt.Sales@ProMachBuilt.com
BarteltPackaging.com

